



9th APCChE Congress

APCChE 2002

Asian Pacific Confederation of Chemical Engineering  
and

Chemeca 2002

30th Annual Australasian Chemical Engineering Conference

29 September to 3 October, 2002

Hosted by the Department of Chemical and Process Engineering,  
University of Canterbury, Christchurch, New Zealand

## Magnetic Fluid Conditioners Eliminate Severe Scale Problem on South China Sea Offshore Oil Platform

### Authors:

- (1) Anthony H Truman – Chemical Engineering Department, Royal Melbourne Institute of Technology University, Australia
- (2) Dr Michael Walmsley – Materials and Process Engineering Department, School of Science and Technology, University of Waikato, New Zealand
- (3) Hj. Azmee Bin Osman – Operations Engineer, PM Operations, Petronas/Carigali Sdn Bhd, Malaysia
- (4) Zulkifli Abdul Rahim – Maintenance Engineer, PM Operations, Petronas/Carigali Sdn Bhd, Malaysia

### Abstract

This paper describes the successful application of newly developed magnetic fluid conditioners (MFC's) in the elimination of scale problems in a major industrial application. This application of magnetic fluid treatment employed a totally new approach to treat the severe scaling problems experienced on one of the Petronas/Carigali of Malaysia (PCSB) South China Sea offshore oil platforms.

Scale is a major problem in many industrial fluid process systems. In this particular instance chemical scale inhibitors have not been able to solve the problem and other potential solutions such as magnetic fluid treatment technology, alternatively known as magnetic fluid conditioning, have been tried. Like all other technologies, magnetic fluid treatment is a science and must be applied in accordance with certain governing principles. Correct application has resulted in many successes, however, there have been numerous incorrect applications resulting in failures that have cast uncertainty over this technology.

This paper describes the scaling problem and the results achieved in the application of Magnetic Fluid Conditioners on one South China Sea offshore oil platform that for many years has experienced extreme scale problems caused by formation water with a high level of scaling salts such as calcite ( $\text{CaCO}_3$ ). Formation water produced in offshore oil production is often very scaling and can result in the need to shutdown offshore platforms on a regular basis for de-scaling of pipes and equipment. This is a very costly process with respect to lost production, decreased efficiency and considerably increased maintenance. Chemical scale inhibitors have been ineffective in the treatment of this problem. Standard commercially available magnetic fluid conditioners have also been tried previously with no benefit observed.

Because of positive reports about the application of MFC's by significant organizations such as the Society of Petroleum Engineers (SPE)<sup>(1)</sup>, the United States Department of Energy<sup>(2)</sup> and the City University of London Chemical Engineering Department<sup>(3)</sup>, many companies are now pursuing a long term solution to their scale problems based on the use of MFC's.

Petronas/Carigali engineers recognized very early in their experience on the South China Sea platform, that there was need for a higher level of scale control than most people had experienced. Therefore, considerable effort has been expended in research studies and on-site trials, to evaluate the problem and trial potential solutions. A number of magnetic fluid treatment trials have been conducted, as well as exhaustive trials of chemical systems. Having arrived at the conclusion that magnetic fluid treatment had the best potential, if engineered correctly, Petronas approached Magnetic Technology Australia, a company that employs a total scientific/engineering analysis approach to each individual application.

Magnetic Technology Australia (MTA) was approached by PCSB in January 1999 with a view to trialing their Scale-X™ MFC's. A long term solution to a long term problem was specified. Magnetic fluid treatment had previously been unsuccessfully applied on this same platform. Employing the approach of magnetic fluid treatment methods 'normally' applied to re-circulating fluid systems had not worked in the once through fluid system existing on this and other offshore platforms.

MTA declined to submit an offer for standard commercially available MFC's as requested, on the basis that MTA believed that standard MFC's would not work because they are engineered to operate only within a limited range of fluid process conditions. MTA provides a total engineered solution, not just a simple off the shelf service, and as a result of this approach, MTA advised that the fluid process and plant conditions on the offshore platform were outside the operating range of the governing parameters of magnetic fluid technology and would need to be modified to bring them within the functional range.

MTA spent two years developing a largely new approach to the application of this technology for use in the oil and gas industry.

Tests on scale formation closely simulating the actual platform conditions were conducted in the laboratory. Development of the technology and a totally new type of equipment took

another six months, always with the window of a major scheduled platform shutdown as the target. On-site trials of these new MFC's were then conducted for eight months commencing in August 2001, treating the most severe scale problems experienced on the platform. Scale in the treated zone was completely eliminated, existing scale was removed and the performance of the Scale-X™ MFC's bettered the PCSB specification in all respects.

### Introduction

The PCSB South China Sea offshore oil platform has had an extreme scale problem for many years, requiring shutdown for de-scaling on a three monthly basis (two shutdowns of 3 days and two of 18 hours each year). The scale is caused by the scaling properties of the formation water. The scale consists of calcite (95%), dolomite (3%) and barite (2%). Chemical inhibitors have proved largely ineffective.

Production drop off over three months between de-scaling shutdowns, due to scale build up restricting production output, was 18%. The scale formed in the various separation vessel outlet standpipes and downstream control valves and non-return valves and in the piping before and after the water treatment corrugated plate interceptors. After the regular 'strip-downs' for mechanical and chemical de-scaling, control valves became non-functional (jammed) within 4 weeks when scale inhibitors were used and within 15 days when scale inhibitors were not used. Twenty-four hour manual operation of the control valves' bypass valves would then be employed.

The PCSB specification required that the MFC's reduce the need for shutdowns from four to one per year, that is, it allowed for the scale to build up at one quarter the existing rate. Also, it specified that the MFC's should require zero or minimal maintenance. An additional requirement not listed in the specification, but added later by PCSB, was that the control valves should remain functional for twelve months, that is, the stroke of the valves (opening and closing the valves) could be reduced because of scale build up but the valves must not become jammed. The existing practice of stroking the valves twice per day to mechanically remove scale could be continued but it would be an advantage if stroking could be eliminated.

### Case History of Actions Taken to Solve the Scale Problem on This Platform

A case history of the scaling problem experienced by this PCSB South China Sea offshore platform is detailed in the Society of Petroleum Engineers International technical paper SPE 60199, presented January 2000. As is seen from a study of this paper, the scaling problem had remained unresolved for many years with an ongoing impact on production output. Various methods had been employed to locate points of scale build up and remove the scale, however, PCSB was unable to stop the build up of scale and the problem still remained a severe issue at some locations.

A short term solution had been reached but this involved shutdowns every three months for de-scaling. These are very costly in terms of lost production, efficiency and maintenance costs. As noted in the SPE paper *"long term cheaper solutions must be pursued despite lack of such proven/cheap options..."*

It is also noted in the SPE paper that one long term measure, a commercially available Magnetic Fluid Conditioner (MFC), had been tried with no benefit observed. A later inspection of the platform revealed a second MFC had been tried, again with no benefit observed.

### Scale Problem Existing Before Scale-X™ MFC's Were Installed

Despite the failure of the two commercially available MFC's, PCSB decided to continue to pursue a long term solution through use of this technology. Magnetic Technology Australia was approached in January 1999 to make a submission as to how scale problems could be resolved. The specification

required that the de-scaling shutdowns should be reduced from 4 to 1 shutdown per year.

This platform has a high water cut and the severe scale problem is caused by the scaling properties of the formation water. At each pressure reduction point in the process CO<sub>2</sub> is released, this affects the solubility of CaCO<sub>3</sub> causing it to precipitate as scale. Scale build up occurs in pipes after the well head choke valves, in the vessel outlet stand pipes, in the control valves and non-return valves and in the pipes particularly those pipes before and after the corrugated plate interceptors. The locations of these scaling points are shown in schematic Diagram No. 1A.

The most severe scale problem on the platform was at the second stage separation vessel (that is, the first oil/water separation vessel) as shown in Diagram No. 1A. This vessel has 3 phase separation, gas/oil/water, and the worst situation for scaling because of the large amount of gas liberated. At each point of pressure reduction gas is liberated, not only at valves but even over pipe fittings and vessel nozzles (entrées and exits and vortex separators). Gas release is a main component in the chemistry of scale production.

Although the first stage pressure let down vessel had separated a large amount of gas, it was apparent that the second stage had still separated significant amounts and at a stage where the liberation of carbon dioxide affected the chemical stability of the dissolved scale forming mineral salts.

The separation vessel was heavily scaled at the 'wind and water' line, which had varied by about a half a meter over the period since last being cleaned. The scale band began adjacent to the vessel inlet, where the inlet impingement baffle had deflected the liquid stream against the dished end. It was about 1cm at its thickest, and flaking off as the vessel dried out during shutdown. It was layered and had the porous appearance due to the large amount of gas liberated during its formation. Also, the vessel had a heavy sludge layer of sand and lumps of scale, which was removed largely by hose jet washing, through the three 6 inch drain nozzles, into a temporary retention bund on the deck.

The heavy build ups of scale formed in the water and oil stand pipes and their vortex breakers and the oil and water flow control valves and non-return valves are shown in Diagram No. 1A. **Note:** at this point in the oil/water separation system the liquid in the oil line is 3 parts crude and 1 part formation water. Scale had virtually plugged the 8inch water outlet, growing inwards in rings of white scale and gray to brown oil and oxide deposits. The vortex breaker baffles were heavily encrusted, particularly in areas of high fluid turbulence.

A sketch detailing the extent of the scale build up in the standpipes before de-scaling is shown in Diagram No. 3.

Photographs (refer Diagram No. 4), showing the scale build up in the oil outlet control valve and the water outlet non-return valve gives an indication of the severity of the scale problem. The control valves became stuck (inoperative) within 4 to 6 weeks after the platform de-scaling shutdown, even though they were stroked twice daily to mechanically remove the scale and chemical scale inhibitors were used. (**Note:** the control valves became stuck within 15 days when scale inhibitors were not used.) An operator was then stationed 24 hours per day at the bypass valves of the flow control valves to manually control liquid levels in the separator vessel.

Before installation of the MFC's, over the three months between shutdowns for de-scaling, the separation vessel pressure was progressively ramped-up a total of 250kPa and the liquid level was raised by a total of 570mm. Even with these operational changes the production output dropped off by 18% over the 3 months between scheduled de-scaling shutdowns. These operational changes are shown in Diagram Nos. 5A, 5B and 5C and the progressive reduction in valve stroke as the valves scale up is shown in Diagram No. 6. It is

obvious from these diagrams why the scale build up caused an 18% drop off in production output.

The primary limiting factor to production for this platform was the restriction to liquid flow caused by rapid scale build up in the flow control valves and the non-return valves. The scale build up in pipes is a major cause of shutdown but is secondary to the control and non-return valve problem with respect to production rate.

Although attention was concentrated on the second stage separator for this installation of MFC's, there is considerable scaling throughout the entire system, from the wells, through the strings and trees and at all stages of separation and water treatment and associated piping. This is to be addressed in the next stage of installations of Scale-X™ MFC's.

### Procedures Taken by Magnetic Technology to Treat This Scale Problem

Magnetic Technology was initially invited to make an offer based on MFC's which are of a similar design to the standard commercially available MFC's which had already been trialled by PCSB but which had produced no observable benefit. Even though, at the time of invitation to offer, Magnetic Technology was unaware of the previous MFC trials carried out by PCSB which had failed, MTA declined to submit an offer on that basis. MTA stated that such MFC's were totally unsuitable for this application and would not solve the problem. This is also the case for many other industrial applications.

Most industrial applications of MFC's are in re-circulating fluid systems, such as cooling water circuits, and there is a cumulative magnetic energy effect due to multiple passes through the applied magnetic fields. For many re-circulating systems applications, even poorly designed MFC's can produce some observable benefits. This is not the case with the offshore oil platform applications that are a once through process, here there is only one 'chance' of effecting a treatment. The large majority of commercially available MFC's are only suitable for small bore re-circulating systems. Radically different specially designed MFC's are required for oil platform applications.

Before making a submission, MTA requested considerably more information on the equipment and fluid process so that a total engineering solution approach could be undertaken to the design of the MFC's. The major factors considered in development of the new MFC's, specifically designed to treat this offshore oil platform scale problem were:

1. Fluid dynamics at each scaling point.
2. The need to modify fluid conditions to bring them into the operational range of the governing parameters of magnetic fluid treatment
3. The incidence and severity of the scaling problem
4. The chemical composition of the scale
5. The mechanisms of scale generation/formation
6. Availability of locations and space for installation of MFC's
7. The relationship between the cause of scaling, the location of the scale generating point and available MFC installation points
8. The fluid process is once through and not re-circulating
9. Velocity ramping of the fluid through the MFC's to produce optimum conditions for rate and duration of magnetic field interaction over a wide range of flow-rates.
10. The zones of treatment relative to available installation locations
11. The structure of the vessels, valves and piping
12. Flow patterns in the vessels and the impact of introducing MFC's on these patterns
13. The overall water cut of the producing wells
14. Materials of the system construction
15. Ease and cost of retrofit
16. The need to incorporate vortex breaker functions
17. The capital cost of the alternative options available
18. The highly corrosive conditions of the fluid process

19. The severe sand problem existing in the system.

A new approach to the problem was required, particularly as to how the magnetic treatment of fluids technology might be applied, from a technical point of view, and with respect to ease of installation and cost.

MTA engaged a process engineering company to advise on the fluid dynamics issues and on how to integrate MFC's into the platform fluid process system without affecting the process and at the same time not introducing its own scale producing problems. It should be noted here that any changes in fluid flow conditions can produce new scale formation problems. Possible impacts on the fluid process were also taken into account

This new approach involved locating the MFC's internally to the vessels and pipes and the incorporation of velocity amplification and flow profiling to modify the fluid dynamics to bring the relevant fluid parameters within the operating range in which magnetic fluid treatment will function. The method of integrating the velocity amplifiers and flow profilers into the MFC's was critical otherwise new scaling points could be generated and the fluid process could be altered. In this particular application, vortex breaker duties were also incorporated into the designs. Careful consideration was given to field structures, field penetration, field strength and the intersection of the field gradient and the fluid velocity vectors. Another major issue was the sourcing of raw materials that would withstand the environmental conditions for the specified period of 10 years.

Various designs were then tested in the NATA accredited laboratory of Thames Water Australia Pty Ltd, that is, a laboratory approved by the National Testing Authority. These included velocity amplifier ratings, magnetic field structures, field gauss ratings, penetration and depth of field and velocity flow profile vectors relative to magnetic field gradients. The platform scale problem and process conditions were accurately simulated and rates of scale build up and crystal structure checked. These tests showed that the new Scale-X™ MFC designs would completely eliminate the worst scale problem being experienced on the platform.

Two prototype Scale-X™ MFC's were developed and manufactured for installation on the oil and water stand pipes of the separation vessel, that is, to treat the most severe scaling problem on the platform. These units were installed in the August 2001 scheduled platform de-scaling shutdown at the points shown in Diagram No. 1B. The vortex breakers were removed and replaced by the MFC's. A photograph of the Scale-X™ MFC installed on the water outlet standpipe is shown in Diagram No. 7.

When the MFC's were installed, the flow control valves and non-return valves were mechanically and chemically cleaned, however, associated piping was not cleaned with the exception of the separation vessel water outlet standpipe that was only partially cleaned.

### The Major Outcomes of the Scale-X™ MFC's Installation

At the time of writing this report, that is, 8 months after installation of the MFC's, the platform had not required a shutdown for de-scaling, but was taken off-line as part of a 5 day general oil field shutdown, an exceptional occurrence. Arrangements were therefore made to take this opportunity to internally visually inspect the Scale-X installation. At this stage (8 months on-line) without the MFC's the platform would have already been shutdown twice for de-scaling (at 3 and 6 months) and would be struggling for production at one month off being shutdown for a third time for de-scaling, however, the platform was still operating at full production output.

The benefits produced by the MFC's were then physically checked and photographed.

It is to be noted that at the time of delivery of the two prototype Scale-X™ MFC's, the PCSB specification only required the MFC's to reduce the rate of scale build up in the stand pipes by half. The requirement to treat the control valves was added later.

The main outcomes of installation of the Scale-X MFC's eight months after installation are:

1. **Elimination of Scale Build-Up:** Scale build-ups in the vessel outlet stand pipes, and downstream control valves have been eliminated. Scale build up was also eliminated in the oil line non-return valve and downstream piping (note that the liquid in the oil line at this point is 3 parts crude and 1 part formation water). Before installation of the MFC's the standpipes became almost 100% blocked with hard scale within the 6 month period between the 3 day major shutdowns and the valves became stuck (inoperable) after 4 weeks when chemical scale inhibitors were used and within 15 days when chemical scale inhibitors were not used.
2. **Existing Scale Removed:** The MFC's have removed pre-existing scale in the stand pipes and the pipes downstream of the oil control valve which was not removed during the shutdown de-scaling carried out before installation of the MFC's. The down stream block valve and pipes are now free of scale.
3. **100% Stroking of Valves:** The oil and water outlet control valves no longer required to be stroked and remained 100% operational, that is, there had been no reduction in the stroke of the valves. These valves had previously been manually operated (stroked) twice daily in an attempt to mechanically remove scale and keep the valves operational.
4. **Ability to Eliminate Need for Scale Inhibitors:** The water control valve was operated without the injection of chemical scale inhibitors. It remained 100% operational and the subsequent physical inspection showed that the valve seat, ball and stem were clean, that is, free of scale build up. Previous to installation of the MFC's the valve became stuck within 15 days when scale inhibitors were not used.
5. **Vessel Liquid Level Unchanged:** The liquid level in the vessel had not been raised. Before installation of the MFC's it had to be ramped up 570mm over the 3 months to try to maintain production output.
6. **Vessel Pressure Unchanged:** The vessel pressure had not needed to be increased. Before installation of the MFC's the pressure was ramped up 250kPa over the 3 month period between shutdowns.
7. **100% Production Output Level Maintained:** There has been no drop off in production output level, that is, the production has remained at 100% since installation of the MFC's. Before installation of the MFC's, the production level dropped off by 18% over the three months between shutdowns.

In all cases, the Scale-X MFC's have more than achieved the requirements set out in the PCSB specification that allowed for some scale build up over twelve months. The scale problem has been eliminated and existing scale is being softened and removed. This is documented graphically in Diagrams Nos. 5A, 5B, 5C and 6 which show how the operational parameters have remained steady, production has been maintained at 100% output and the control valves' stroke has remained "fully open to fully closed" without twice daily stroking.

Diagram No. 2 show photographs of the oil control valve, non return valve and block valve reducer down stream of the control valve at 3 months without MFC's installed and at 8 months with MFC's installed. These graphically demonstrate how the MFC's have totally eliminated the severe scale build up.

A summary of the benefits arising from the installation of the MFC's is given in Diagram No. 8.

The PCSB specification requirement of an annual shutdown only has been exceeded. In light of the outcomes, so far, it is expected that with a full system of Scale-X™ MFC's installed on this platform, the platform will be able to run continuously without the need to shutdown for de-scaling. That is, even the yearly shutdown to de-scale could be eliminated.

## Conclusions

Elimination of scale in the valves as well as the piping was a major achievement. PCSB had, from previous experience, obviously not expected that the scale problem could be totally eliminated and existing scale softened and removed. These new MFC's have created a new perspective, and raised expectations with respect to what this technology can achieve, to a new level.

The application of Scale-X™ Magnetic Fluid Conditioners on the PCSB South China Sea offshore oil platform has shown that:-

1. Scale-X™ MFC's can eliminate very severe scaling problems in large industrial applications including offshore oil platform production systems.
2. Magnetic fluid treatment technology must be applied in a scientific way
3. This technology must be designed to suit the individual application
4. Fluid systems involving a single pass through the MFC will be effective provided the MFC's and the system are engineered correctly
5. A standard (typical) approach to the application of this technology will fail in many applications because they are engineered to operate only within a limited range of fluid process conditions and many industrial fluid process systems operate outside that range
6. Where fluid dynamics and the fluid process parameters are not within the operating range of this technology, velocity amplifiers and flow profiling must be incorporated into the MFC's
7. It is possible to design MFC's which are simple to retrofit in large industrial applications and are low in capital cost
8. Scale can be totally eliminated in major industrial plants resulting in the plants running continuously without the need for shutdowns to de-scale
9. The MFC's commonly available in the market place are generally not suitable for application in major industrial applications.

## References

- (1) "Study of Paraffin Crystallisation Process Under the Influence of Magnetic Fields and Chemicals" – SPE38990, Society of Petroleum Engineers – September 1997 by L C C Marques, N O Rocha, A L C Machado, G B M Neves, L C Vieira and C H Ditz – Petrobras Research Center, RJ.
- (2) Federal Technologies Alerts – "Non-Chemical Technologies for Scale and Hardness Control" by the United States Department of Energy – January 1998
- (3) "Lifting the Scale from Our Pipes" – New Scientist 18 February 1988 – Professor John Donaldson and Dr Sue Grimes – Chemistry Department, City University London

## Acknowledgements

These new magnetic fluid conditioners (MFC's) were developed by Magnetic Technology Australia and are marketed under the name Scale-X™ Magnetic Fluid Conditioners. Further information can be obtained from

[www.scale-x.com](http://www.scale-x.com).

Diagram No.1A

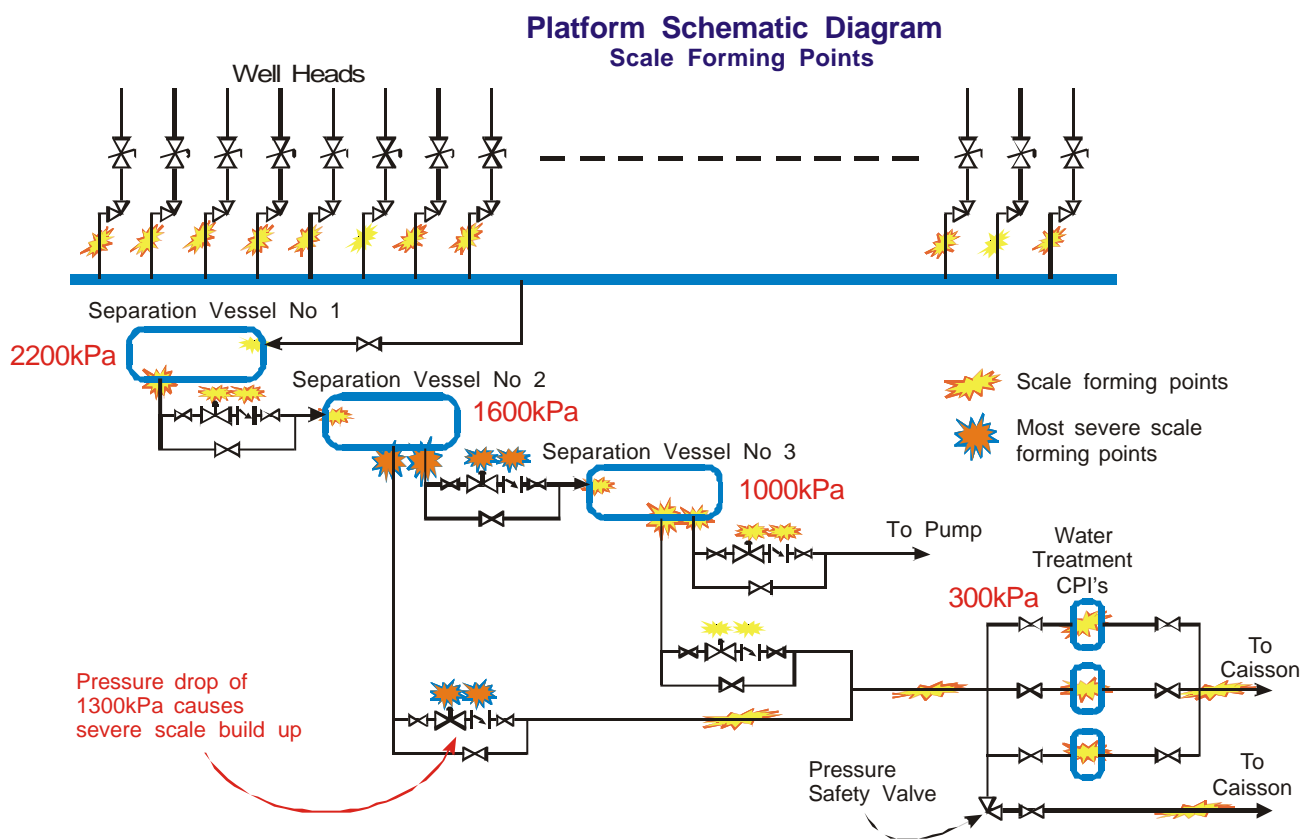

Diagram No.1B

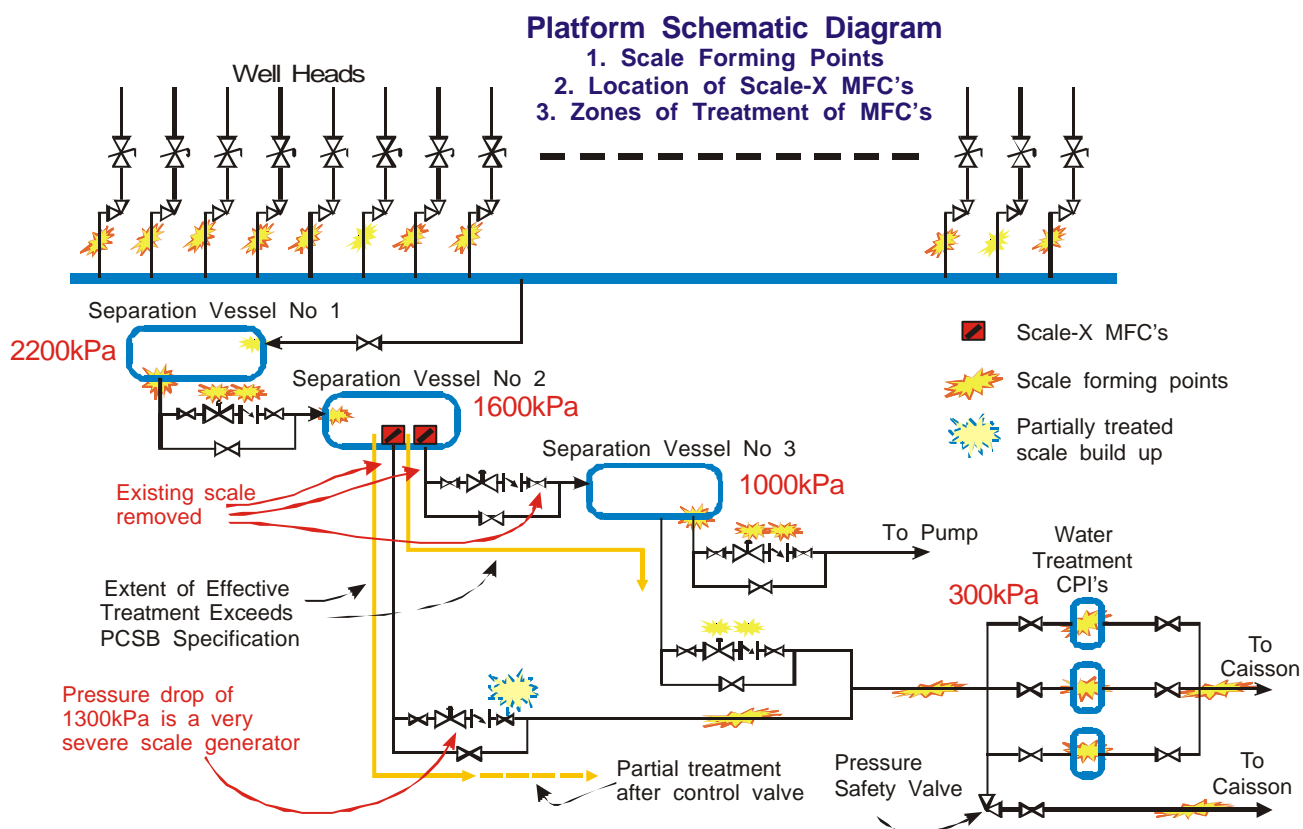
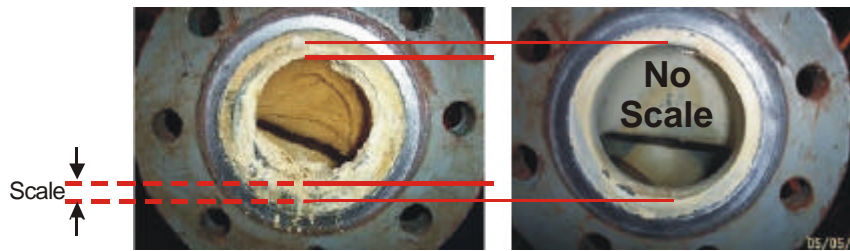

Diagram No.2

**Oil Control Valve**



Thick Scale Build Up  
After 3 Months  
Without MFC's Installed

No Scale Build Up  
After 8 Months  
With MFC's Installed

**Non-Return Valve**

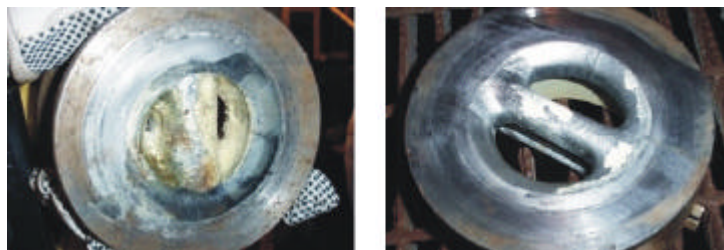

Heavy Scale Build Up  
After 3 Months  
Without MFC's Installed

No Scale Build Up  
After 8 Months  
With MFC's Installed

**Block Valve Reducer Downstream  
of Oil Control Valve**

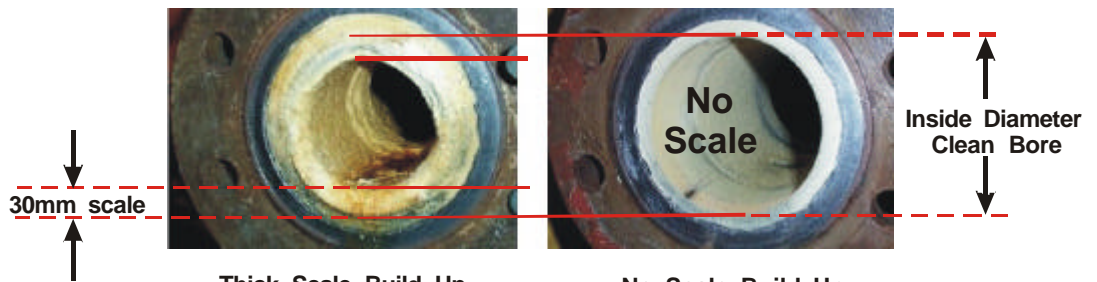

Thick Scale Build Up  
After 3 Months  
Without MFC's Installed  
Thickness of Scale is 30mm

No Scale Build Up  
After 8 Months  
With MFC's Installed  
Scale is eliminated

**NOTE: The liquid through these valves and reducer is 3 parts crude oil and 1 part formation water.**

Diagram No.3

**Oil/Water/Gas Separation Vessel  
Oil and Water Standpipes  
Scale Build Up Before De-scaling  
Without MFC's Installed**

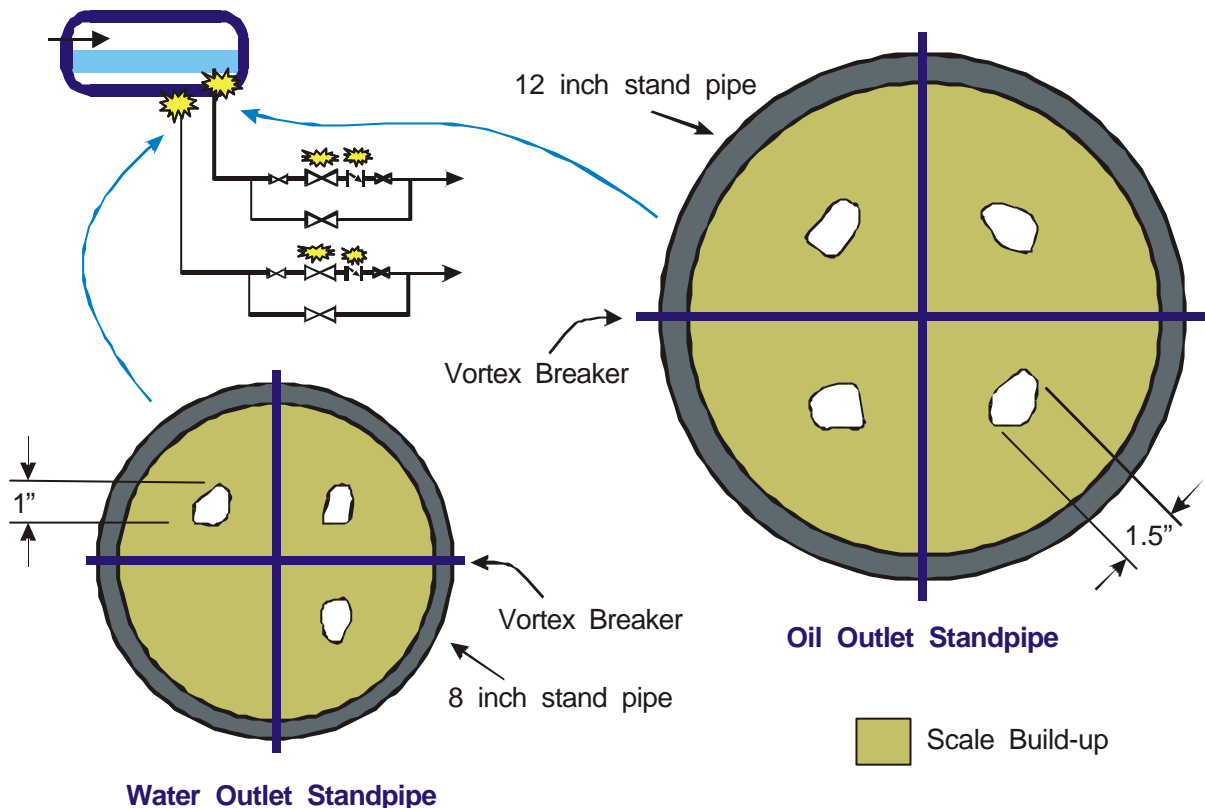

Diagram No.4

**South China Sea Offshore Platform  
Oil & Water Separation System  
Severe Scaling Problem**

**Scale Build Up After 3 Months  
Without MFC's Installed**

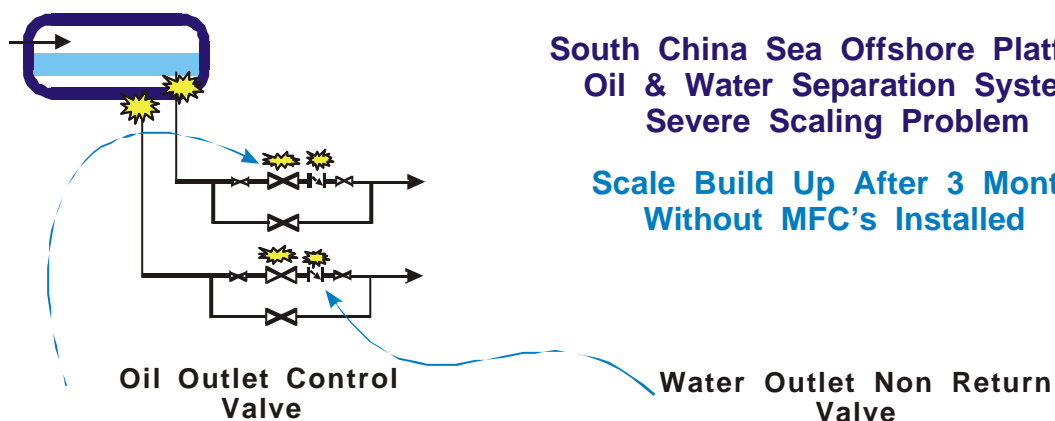

Diagram No.5A

**Production Output Level  
Operation of South China Sea Offshore Oil Platform  
Without and With Scale-X MFC's**

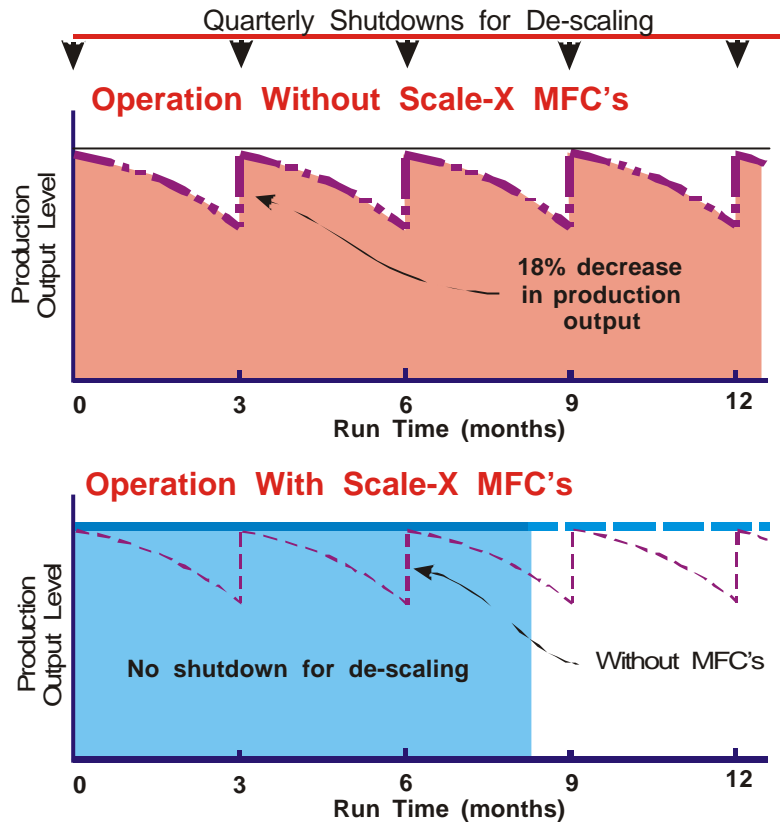

Diagram No.5B

**Vessel Operating Liquid Level  
Operation of South China Sea Offshore Oil Platform  
Oil & Water Separation Vessel  
Without and With Scale-X MFC's**

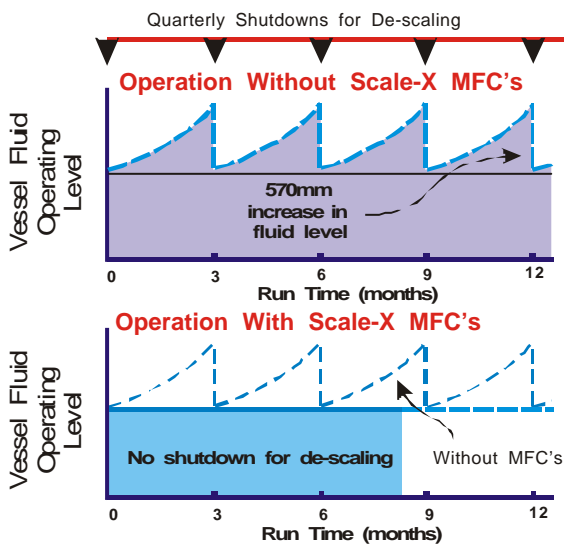

Diagram No.5C

**Vessel Operating Pressure  
Operation of South China Sea Offshore Oil Platform  
Oil & Water Separation Vessel  
Without and With Scale-X MFC's**

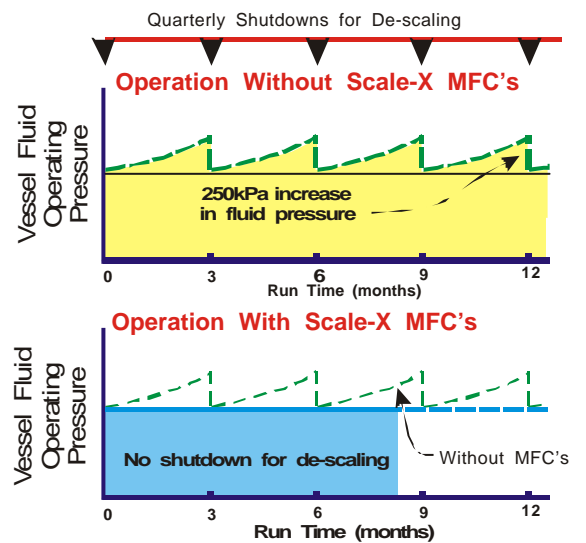
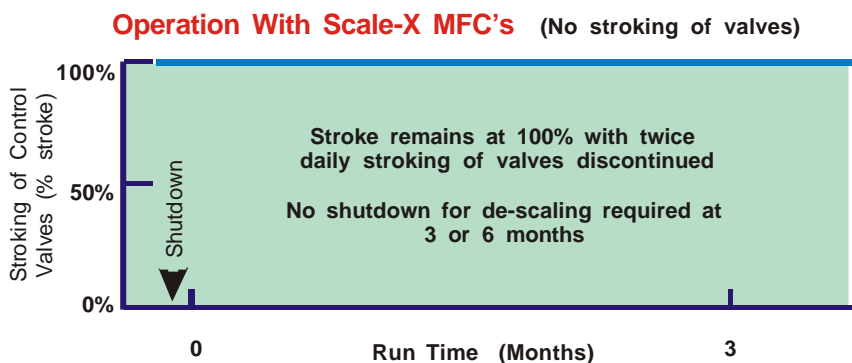
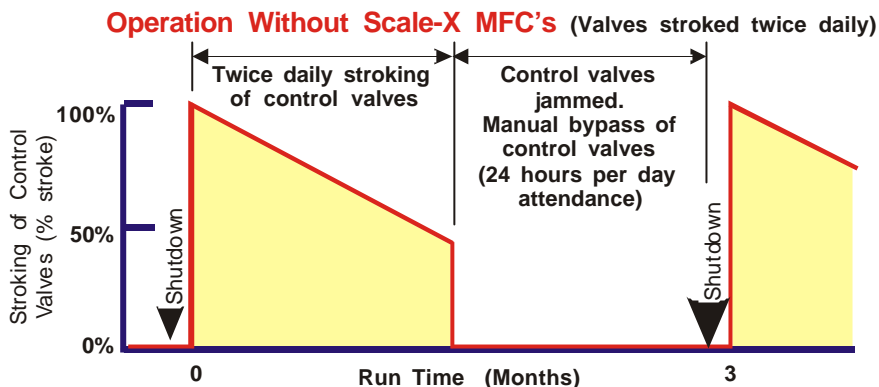

Diagram No.6

**Stroking of Flow Control Valves  
Oil & Water Separation Vessel Control Valves  
Without and With Scale-X MFC's**



**Eight Month Overview**

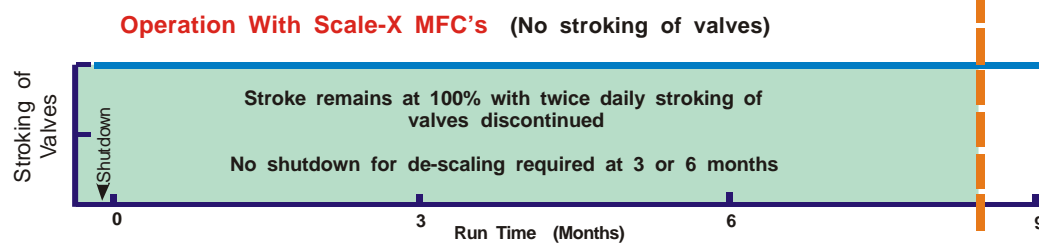
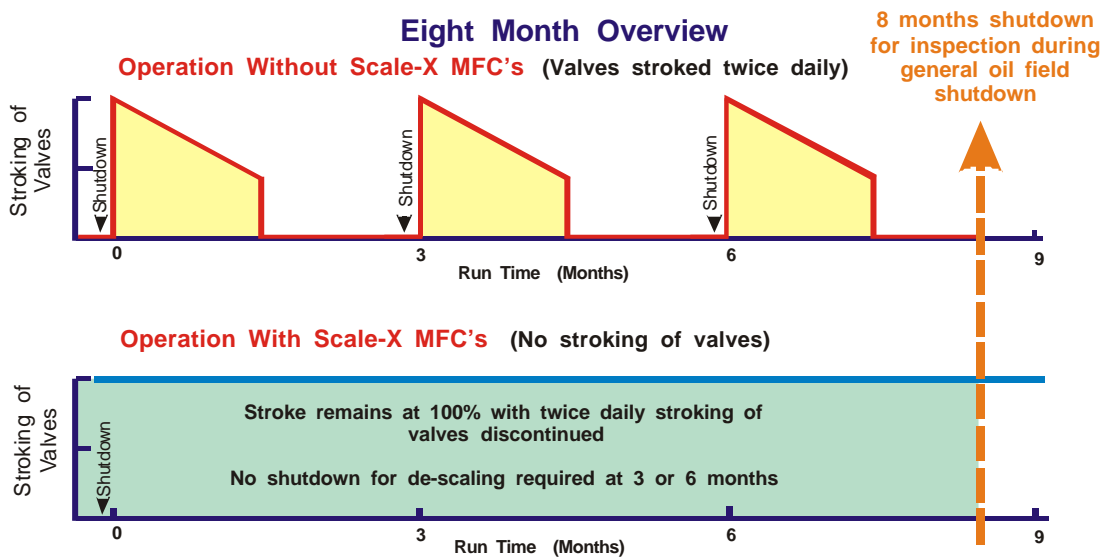

Diagram No.7

**Scale-X™ MFC  
Installed on the  
Separation Vessel  
Water Outlet Standpipe**



Diagram No.8

## Condition of Standpipes, Valves and Pipes Before and After Installation of Scale-X MFC's on Offshore Oil Platform

